

Martin Super Pac Installation Instructions

- Carefully slip the housing onto the shaft.
 - * Use **ONLY** mild soapy water for lubrication.
- Align housing **flush** to Endplate.
 - Housing must be **perpendicular - normal** to the shaft.
 - *Alignment of housing to shaft cannot exceed 2°.
- Check for equal spacing around the shaft and the ID of the seal.
- Tighten mounting hardware to manufacturers recommended torque settings.
- If purge required for application, purge seal before operating .
 - *Operating temperature range: - 30°F to + 450°F

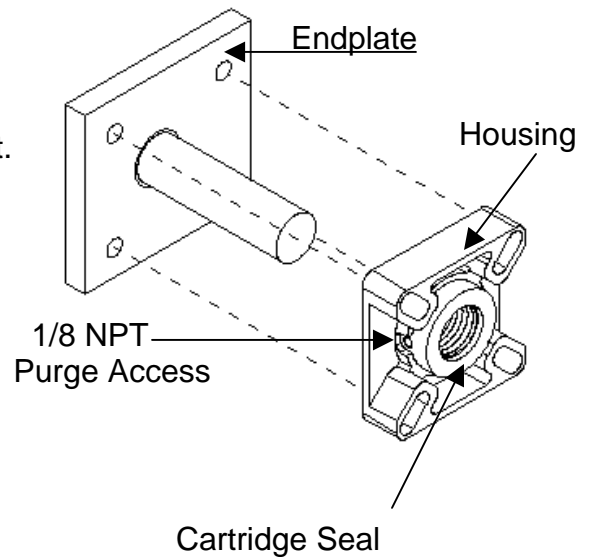

Purge options available:

Purge option: 1 Air Purge using an Air Regulator.

Purge option: 2 Silicone Grease Purge.

Option 1: Using an Air Purge with regulator

Port size: 1/4 * Use bushing provided to mate 1/8 male fitting of cartridge.

Gauge ports: 1/8 (2 Ports available for orientation convenience)

*Place small plug provided, in unused 1/8 opening on air regulator.

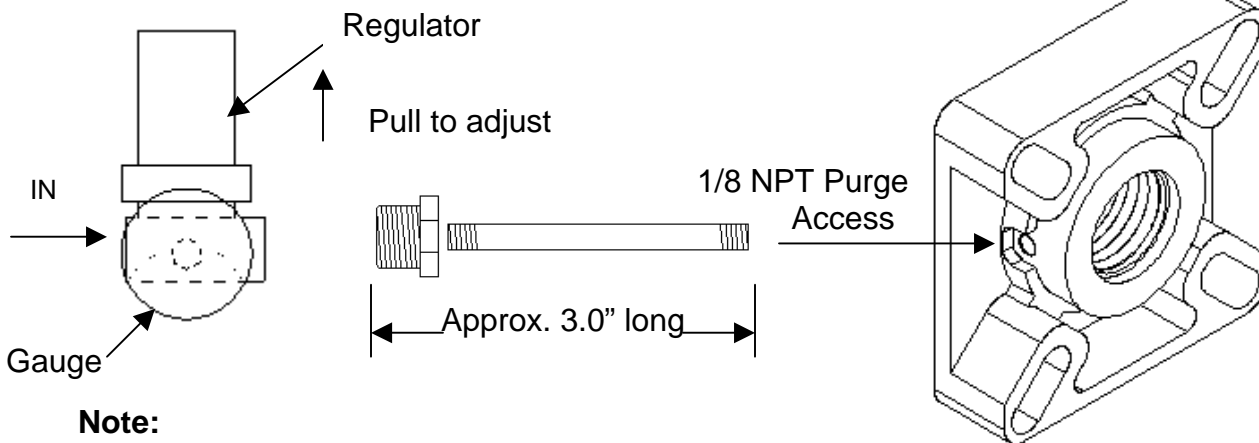

Note:

Airflow to be set 5-10 psi above internal pressure of conveyor. Max air pressure of seal is 50 psi.

Option 2: Silicone Grease Purge

*Use silicone grease **ONLY**.

